

Surname	Centre Number	Candidate Number
Other Names		2



GCE A level

1145/01



S15-1145-01

ELECTRONICS – ET5

A.M. TUESDAY, 16 June 2015

1 hour 30 minutes

For Examiner's use only		
Question	Maximum Mark	Mark Awarded
1.	7	
2.	9	
3.	5	
4.	11	
5.	8	
6.	8	
7.	6	
8.	7	
9.	9	
Total	70	

ADDITIONAL MATERIALS

In addition to this examination paper, you will need a calculator.

INSTRUCTIONS TO CANDIDATES

Use black ink or black ball-point pen.

Write your name, centre number and candidate number in the spaces at the top of this page.

Answer **all** questions.

Write your answers in the spaces provided in this booklet.

INFORMATION FOR CANDIDATES

The total number of marks available for this paper is 70.

The number of marks is given in brackets at the end of each question or part-question.

You are reminded of the necessity for good English and orderly presentation in your answers.

You are reminded to show all working. Credit is given for correct working even when the final answer given is incorrect.

1145
010001

INFORMATION FOR THE USE OF CANDIDATES

Preferred Values for resistors

The figures shown below and their decade multiples and sub-multiples are the E24 series of preferred values.

10, 11, 12, 13, 15, 16, 18, 20, 22, 24, 27, 30, 33, 36, 39, 43, 47, 51, 56, 62, 68, 75, 82, 91.

Standard Multipliers

Prefix	Multiplier
T	$\times 10^{12}$
G	$\times 10^9$
M	$\times 10^6$
k	$\times 10^3$

Prefix	Multiplier
m	$\times 10^{-3}$
μ	$\times 10^{-6}$
n	$\times 10^{-9}$
p	$\times 10^{-12}$

Alternating Voltages

$$V_o = V_{\text{rms}} \sqrt{2}$$

Silicon Diode

$$V_F \approx 0.7V$$

Operational amplifier

$$G = -\frac{R_F}{R_{IN}}$$

Inverting amplifier

$$G = 1 + \frac{R_F}{R_1}$$

Non-inverting amplifier

$$V_{OUT} = V_{DIFF} \left(\frac{R_F}{R_1} \right)$$

Difference amplifier

$$V_{OUT} = -R_F \left(\frac{V_1}{R_1} + \frac{V_2}{R_2} + \frac{V_3}{R_3} \right)$$

Summing amplifier

$$V_L \approx V_Z \left(1 + \frac{R_F}{R_1} \right)$$

Stabilised power supply

Emitter follower

$$V_{OUT} = V_{IN} - 0.7V$$

Filters

$$f_b = \frac{1}{2\pi RC}$$

Break frequency for high pass and low pass filters

$$X_C = \frac{1}{2\pi fC}$$

Capacitive reactance

Thyristor phase control

$$\phi = \tan^{-1} \frac{R}{X_C}$$

$$\tan \phi = \frac{R}{X_C}$$

Signal conversion

$$\text{resolution} = \frac{\text{i/p voltage range}}{2^n}$$

ADC

Power amplifier

$$P_{MAX} = \frac{V_S^2}{8R_L}$$

where V_S is the rail-to-rail voltage

PIC Information

The PIC programs include 'equate' statements that define the following labels:

Label	Description
PORTA	input / output port A
PORTB	input / output port B
TRISA	the control register for port A
TRISB	the control register for port B
STATUS	the status register
INTCON	the interrupt control register
W	the working register (= h '0')
F	the file register (= h '1')
RP0	the register page selection bit 0
Z	the zero flag status bit
GIE	the global interrupt controller bit
INTE	the external interrupt enable bit

Pinout for 16F84 PIC IC:

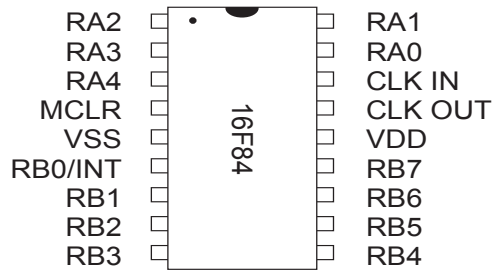

List of commands:

Mnemonic	Operands	Description
bcf	f, b	Clear bit b of file f
bsf	f, b	Set bit b of file f
btfss	f, b	Test bit b of file f, skip next instruction if bit is set
call	k	Call subroutine k
clrf	f	Clear file f
goto	k	Branch to label k
movf	f, d	Move file f (to itself if d = 1, or to working register if d = 0)
movlw	k	Move literal k to working register
movwf	f	Move working register to file f
retfie		Return from interrupt service routine and set global interrupt enable bit GIE

Comparison of TASM and MPASM languages:

Version		TASM	MPASM
Number system notation	Decimal	153	d'153'
	Hex	\$2B	h'2B' or 0x2B
	Binary	%10010110	b'10010110'
Opcode Notation		.equ	equ
		.org	org
		.end	end
		label:	label

Structure of the INTCON register

Bit 7	Bit 6	Bit 5	Bit 4	Bit 3	Bit 2	Bit 1	Bit 0
GIE	EEIE	TOIE	INTE	RBIE	TOIF	INTF	RBIF

Structure of the STATUS register

Bit 7	Bit 6	Bit 5	Bit 4	Bit 3	Bit 2	Bit 1	Bit 0
IRP	RP1	RP0	TO	PD	Z	DC	C

Answer all questions.

1. (a) An eight bit ripple counter can produce false outputs at high pulse frequencies.

Explain a likely cause for these false readings.

[1]

.....

.....

.....

.....

- (b) A sequence generator exhibits the behaviour shown in the table.

Current Outputs				Next Outputs		
State	C	B	A	D _C	D _B	D _A
0	1	0	0	0	0	0
1	0	0	0	1	1	1
2	1	1	1	0	1	1
3	0	1	1	1	0	0
4	0	0	1	0	0	1
5	0	1	0	1	1	0
6	1	1	0	1	1	1
7	1	0	1	1	0	0

- (i) Complete the diagram to show only the main sequence.

[1]

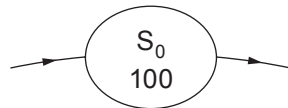

(ii) Identify the stuck state. [1]

.....

(iii) Identify an unused state that is not the stuck state. [1]

.....

(iv) The sequence is controlled by a 1 Hz clock pulse generator.
State what happens, over the three seconds following power up:

- when the system starts in state 5; [2]

.....

- when the system starts in state 4. [1]

.....

.....

2. (a) A sequence generator obeys the following Boolean expressions:

$$D_C = \bar{A}$$

$$D_B = \overline{A + C}$$

$$D_A = B \oplus C$$

Complete the circuit diagram for this sequence generator.

[5]

(Credit will be given for using the minimum number of gates, and correct circuit symbols.)

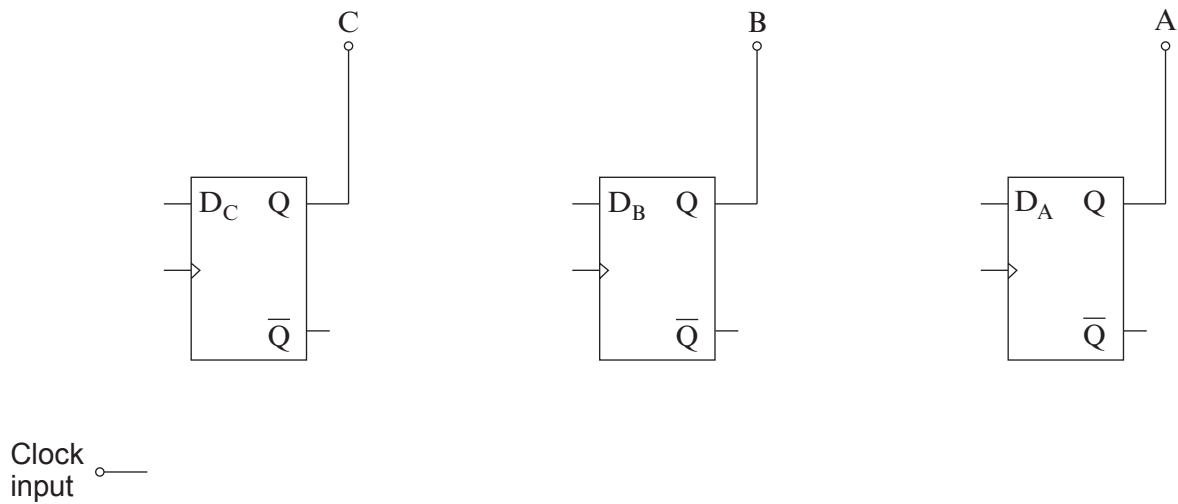

- (b) In an industrial mixer a liquid is pumped into a tank, stirred by a paddle and tipped out using a solenoid.

It is controlled by an electronic system which uses a sequence generator with a 0.1 Hz clock. This controls four outputs – a light, a pump, a paddle and a solenoid.

Each switches on when it receives a logic 1 signal.

It operates these outputs in the following sequence:

- all four outputs are off initially;
- after ten seconds, the light turns on and then stays on;
- ten seconds later, the pump operates for twenty seconds;
- when the pump has been on for ten seconds, the paddle stirs the liquid for a further twenty seconds;
- once the paddle stops, the solenoid operates for ten seconds to tip the tank;
- all outputs turn off and the sequence then repeats.

Complete the table to show the main sequence for this sequence generator.
(You may not need all the rows in the table.)

[4]

Current State					Next State			
State	Light	Pump	Paddle	Solenoid	Light	Pump	Paddle	Solenoid
0	0	0	0	0				

3. The position of a rotating shaft in a machine tool is monitored by a control system using an optically encoded disc. When the shaft stops rotating with the two segments marked as 'danger area' at the bottom, a siren sounds.

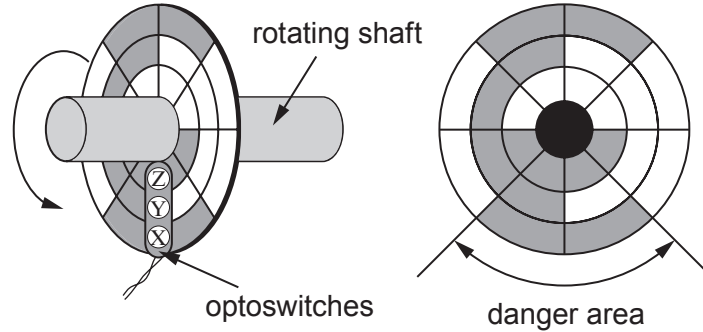

- (a) (i) What is the name of the code used on this disc? [1]

.....

(ii) What is the advantage of using this code rather than binary code in this application? [1]

.....

- (b) The shaded areas on the disc cause the optoswitches to produce an output of logic 1.
- The control system uses the output ZYX of the optoswitches to check where the shaft comes to rest. A siren is connected to the output Q of the control system, and sounds when it receives a logic 1 signal.

Complete the Boolean expressions to show the logic that must be applied to the outputs Z, Y and X, of the optoswitches to drive the siren. [2]

Q =

- (c) Another type of sensor uses a slotted disc, but this is unsuitable for this application. Describe a situation where the slotted disc would be suitable. [1]

.....

.....

4. (a) (i) Complete the circuit diagram for a voltage regulator based on a zener diode, an emitter follower and a non-inverting amplifier. [3]

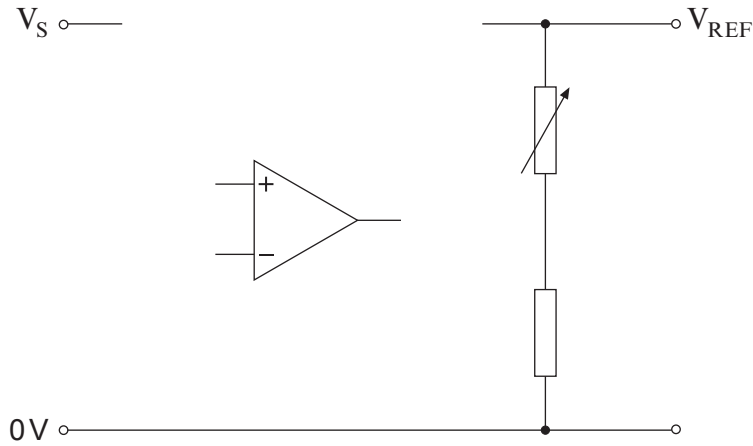

The sub-system containing the zener diode provides *line regulation*.

- (ii) Explain what is meant by *line regulation*. [1]

.....

.....

- (iii) Explain how this sub-system provides line regulation by describing what happens when the supply voltage V_S increases. [1]

.....

.....

.....

.....

- (b) The output of the voltage regulator is used as the reference voltage, V_{REF} , for a 2-bit flash converter. The performance of the ADC is summarised in the following diagram:

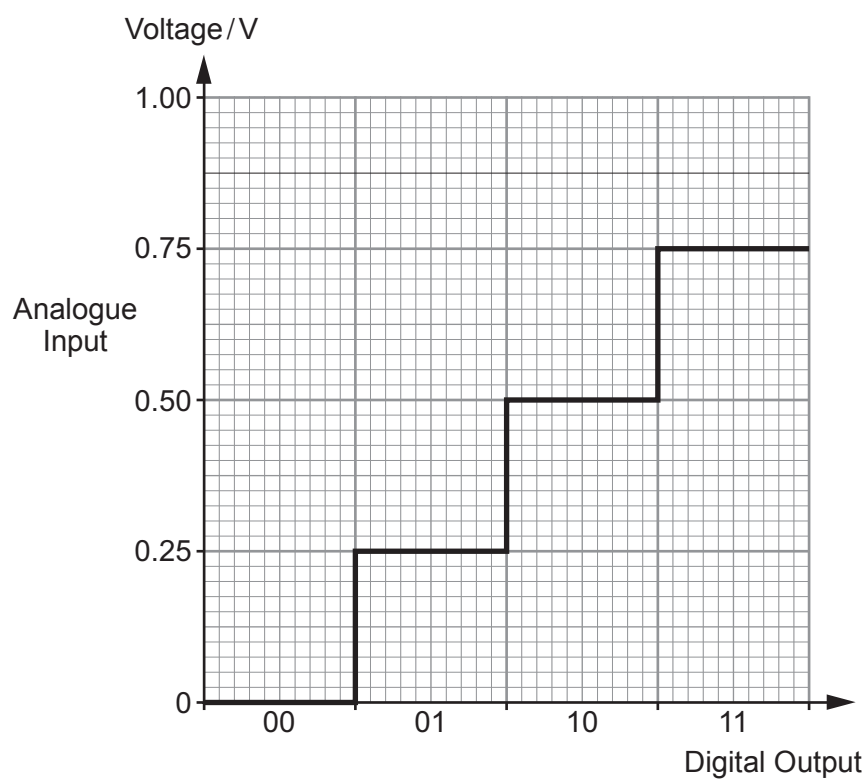

- (i) Complete the circuit diagram for a 2-bit flash converter.

[2]

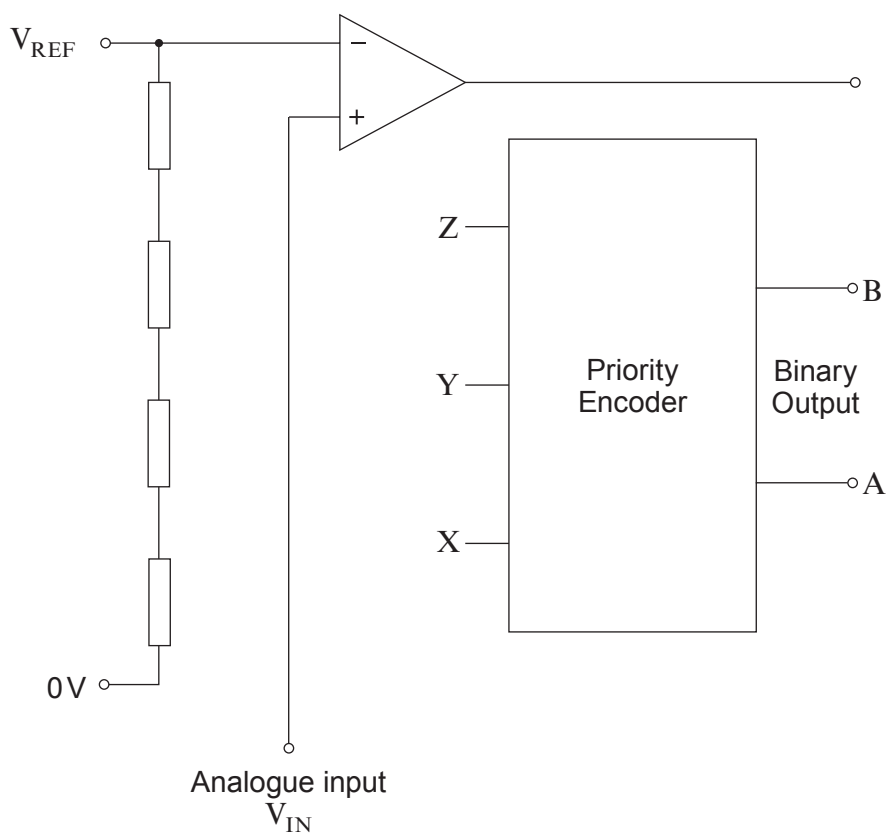

- (ii) Label all resistors with suitable values. [2]
- (iii) What is the value of voltage V_{REF} ? [1]
- (iv) The circuit diagram for the Priority Encoder is shown below.

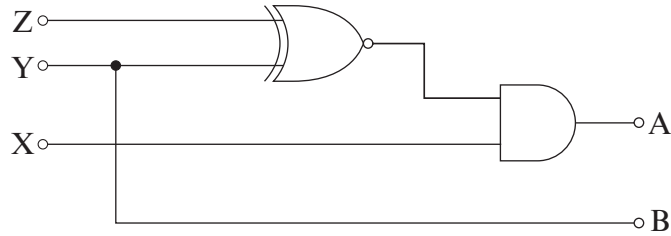

What is the output BA of the converter when $X = 1$, $Y = 1$ and $Z = 0$? [1]

B =

A =

5. A student designs a control system to switch on a reading lamp automatically when it gets dark.

In addition, it warns that an intruder has entered the room by flashing the lamp repeatedly until a concealed switch is pressed. The intruder alert is triggered by a pressure pad in the doorway.

- The lamp is connected to Port B. It switches on when it receives a logic 1 signal.
- The pressure pad is connected to Port B, bit 0. It causes an external interrupt when pressed.
- The concealed reset switch, connected to Port A, bit 0, outputs a logic 1 signal when pressed.

The following code is used to configure the ports.

```

bsf          STATUS,RP0
movlw       b '11111'
movwf      TRISA
movlw       b '01111111'
movwf      TRISB
bcf          STATUS,RP0

```

The following instructions are stored in the microcontroller:

Address	Operator	Operand
00	goto	start
04	goto

The main program follows the label 'start'.

The Interrupt Service Routine is given below. It contains a subroutine called 'onsec', which causes a one second delay, during which the number '4' is written into the working register. After execution of the subroutine, the Working Register, W, contains the binary number '00000100'.

Address	Label	Operator	Operand	Comment
100	warn	movlw	b '.....'	;switch on lamp
101		PORTB	
102		call	onsec	;wait for one second
103		clrf	PORTB	
104		call	onsec	;wait for one second
105		btfs	PORTA,0	
106		goto	warn	
107		retfie		

- (a) Complete the instruction found at address 04. [1]

```

04      goto      .....

```

- (b) Complete the instructions at addresses 100 and 101 to switch on the lamp. [2]

```

100     warn      movlw      b '.....' ;switch on lamp
101     .....     PORTB

```

(c) What is the effect of the instruction at address 103? [1]

.....

.....

(d) When the program is interrupted, the Working Register, W, contains the decimal number 64 (01000000₂).

What number does it contain when it leaves the Interrupt Service Routine? [1]

.....

(e) The student finds that this Interrupt Service Routine causes the main program to malfunction.

The Interrupt Service Routine is modified to correct this problem:

- the Working Register is protected when the microcontroller enters the Interrupt Service Routine, using a file called Wstore;
- a new instruction is added in line 108.

(i) Complete lines 99 and 107 to protect the Working Register in this way. [2]

Address	Label	Operator	Operand	Comment
99	warn	
100	loop	movlw	b '.....'	;switch on lamp
101		PORTB	
102		call	onsec	;wait for one second
103		clrf	PORTB	
104		call	onsec	;wait for one second
105		btfss	PORTA,0	
106		goto	loop	
107		
108		bcf	INTCON,1	
109		retfie		

(ii) What would be the effect on the program of missing out the instruction 'bcf INTCON, 1', given on line 108? [1]

.....

.....

BLANK PAGE

6. The diagram shows a strain gauge unit bonded to part of a building to monitor movement of the structure.

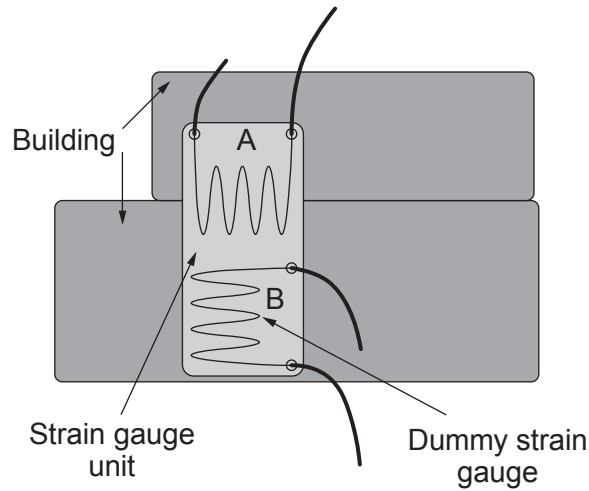

- (a) The two strain gauges, A and B, together with two variable resistors, X and Y, are connected in a bridge circuit, so that if movement occurs in the expected direction, the output voltage V_{OUT} of the bridge circuit increases.

Complete the circuit diagram for this bridge circuit.

Make sure you label the components with either A, B, X or Y.

[2]

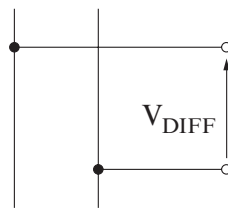

- (b) The strain gauge unit is exposed to strong sunlight, and warms up. As a result, the resistance of the strain gauges increase. Why is there little or no change in V_{DIFF} ? [1]
-
-

- (c) The output of the strain gauge unit, V_{DIFF} , is connected to a difference amplifier, based on an op-amp.

- (i) Complete the circuit diagram for the difference amplifier. [2]

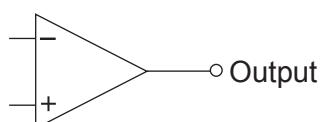
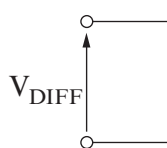

(ii) The difference amplifier has a voltage gain of 200.

Label all the resistors you have added to the circuit diagram with suitable resistance values.

The space below is provided for you to make suitable calculations. [2]

.....

.....

.....

.....

(iii) Calculate the output voltage of the difference amplifier when $V_{DIFF} = 3.5\text{mV}$. [1]

.....

.....

7. Here is part of a data sheet for a thyristor.

Property	Typical value
Maximum forward current	20 A
Holding current	150 mA
Minimum gate current	5 mA
Minimum gate voltage	2.5 V
Peak reverse voltage	1000 V

(a) A thyristor is used in a DC control system. Three of the following conditions will make the thyristor begin to conduct, without necessarily latching.

	Condition	Value
A.	Anode / cathode bias	Forward biased
B.	Anode / cathode bias	Reverse biased
C.	Anode / cathode current	1 A
D.	Anode / cathode current	120 mA
E.	Gate current	2 mA
F.	Gate current	10 mA
G.	Gate voltage	0.5 V
H.	Gate voltage	2.8 V

(i) Select the **three** conditions which will make the thyristor begin to conduct, without necessarily latching. [1]

.....

(ii) What additional condition would ensure that the thyristor latched on and maintained conduction? [1]

.....

(b) The diagram shows a functioning circuit in which a thyristor is used to control a heater.

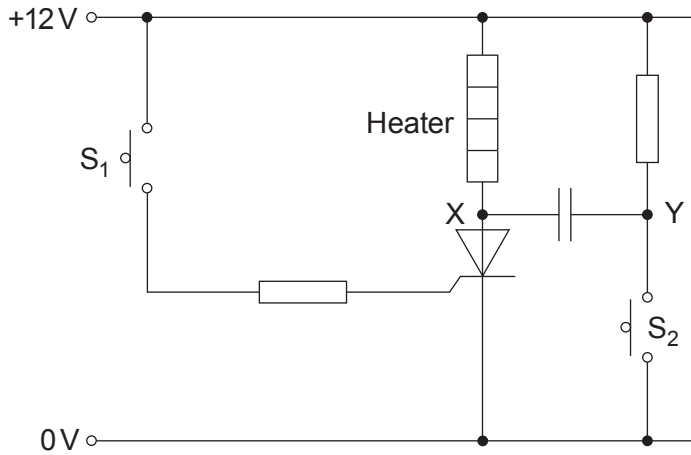

(i) Initially, the heater is switched off, and switch S_2 is open.

State the voltage at:

[1]

X;

Y.

(ii) Switch S_1 is closed momentarily, and switch S_2 remains open.

State the voltage at:

[1]

X;

Y.

(iii) Switch S_1 is open, and switch S_2 is closed momentarily.

I. State the instantaneous voltage at:

[1]

X;

Y.

II. What is the effect of this on the circuit?

[1]

.....

8. The diagram shows a lamp dimmer circuit, using a thyristor.

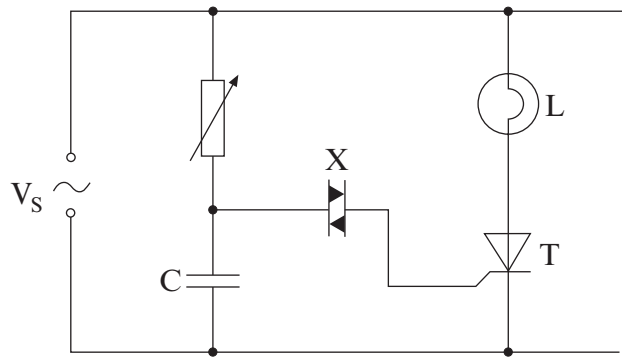

(a) Here are six voltage/time graphs showing different signals. Graph 1, and the dotted traces in the other graphs, show the AC mains supply.

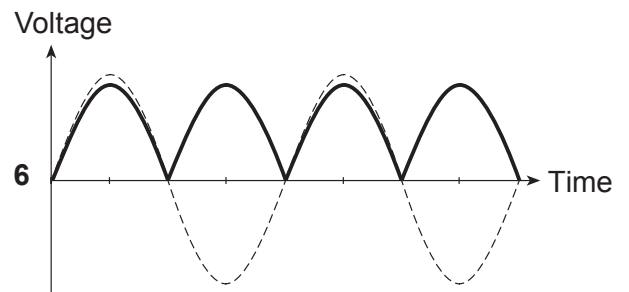
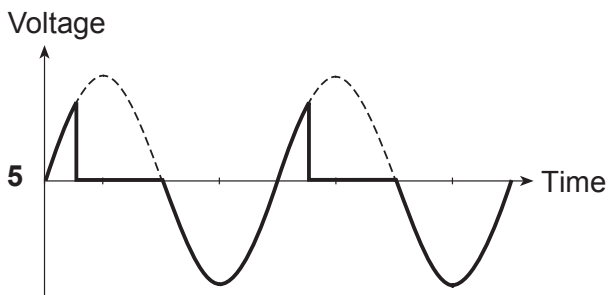
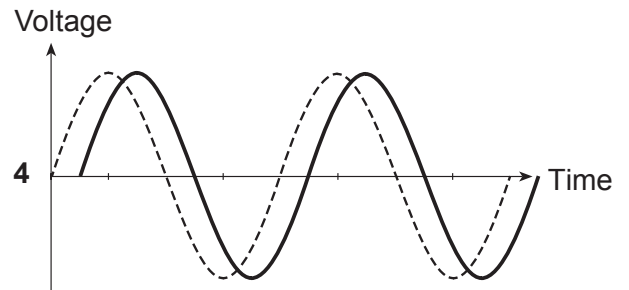
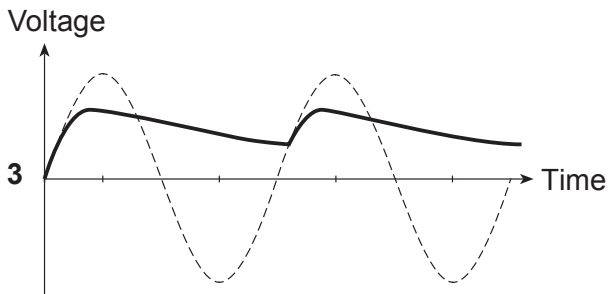
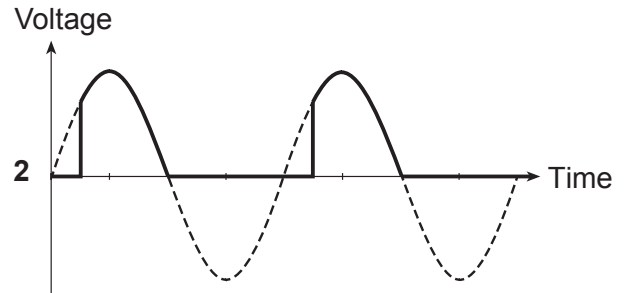
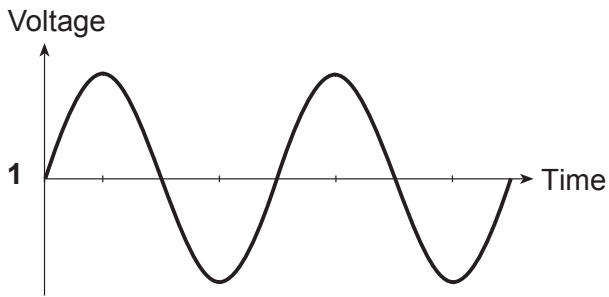

(i) Which graph best represents the signal across the capacitor C ?

.....

(ii) Which graph best represents the signal across the thyristor T ?

.....

(iii) Which graph best represents the signal across the lamp L ?

.....

[3]

(b) (i) What is the name of the component labelled X ?

[1]

(ii) Here are five statements about the purpose of the component labelled X .
Which one is true?

- A. It protects the thyristor against back e.m.f. when the lamp switches off.
- B. It reduces power dissipation in the lamp.
- C. It improves the rise time of the signal at the gate terminal.
- D. It reduces the firing angle of the thyristor.
- E. It increases voltage regulation in the dimmer circuit for a given phase shift.

.....

[1]

(c) The variable resistor is set to a resistance of $5\text{ k}\Omega$. The capacitor has a capacitance of $22\text{ }\mu\text{F}$.

Calculate the phase shift ϕ between the supply voltage V_S and the voltage across the capacitor when the power supply frequency is 50 Hz .

[2]

.....
.....

9. Here is the block diagram for a public address system.



(a) The tone controls sub-system includes the following bass boost filter:

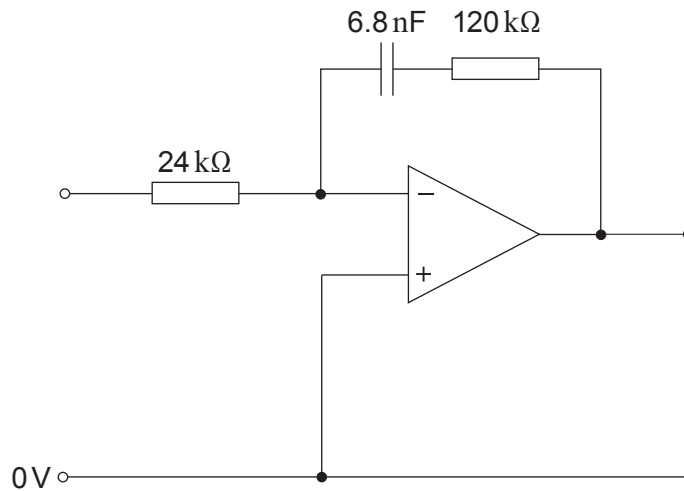

(i) Calculate the break frequency for this filter.

[1]

(ii) Calculate its voltage gain at a frequency much higher than this break frequency.

[1]

- (iii) Use this information to draw the frequency response for this filter.

[3] Examiner
only

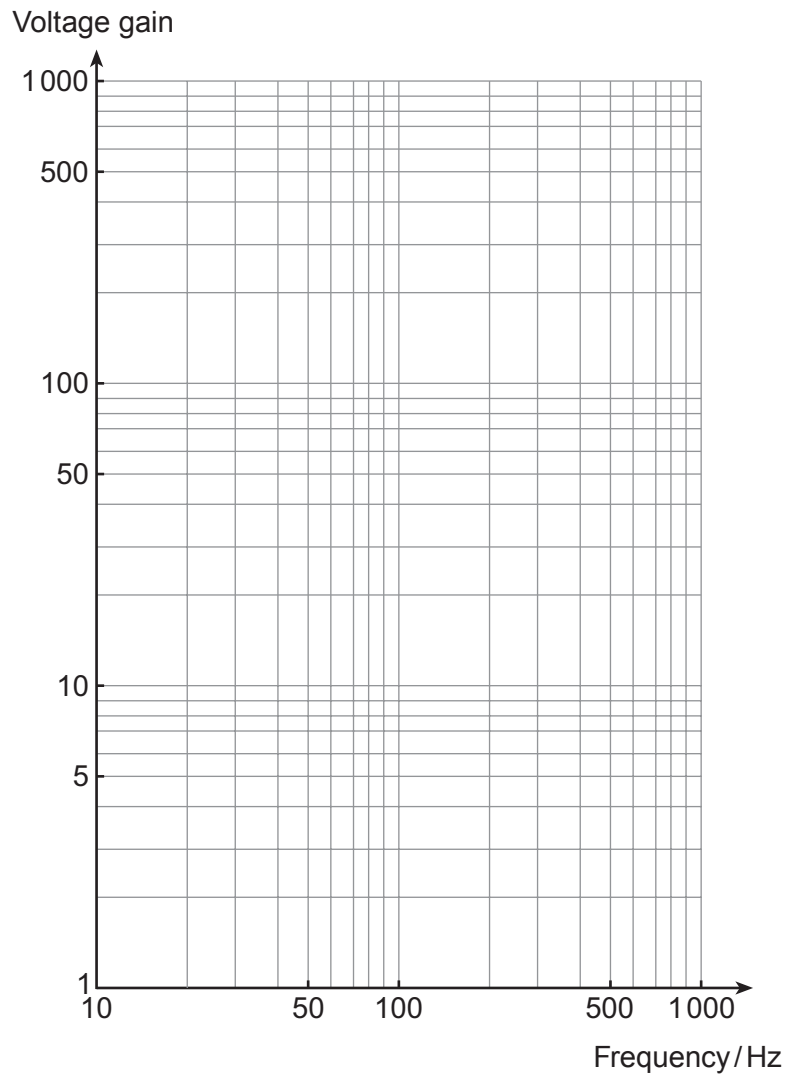

(b) The power amplifier incorporates the following circuit:

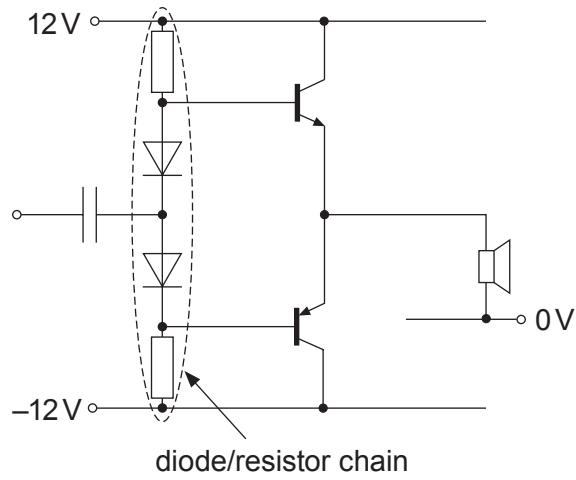

(i) What is the purpose of the diode/resistor chain?

[1]

.....

.....

.....

- (ii) The graph shows part of the input signal for this circuit. Sketch the corresponding output signal. [2]

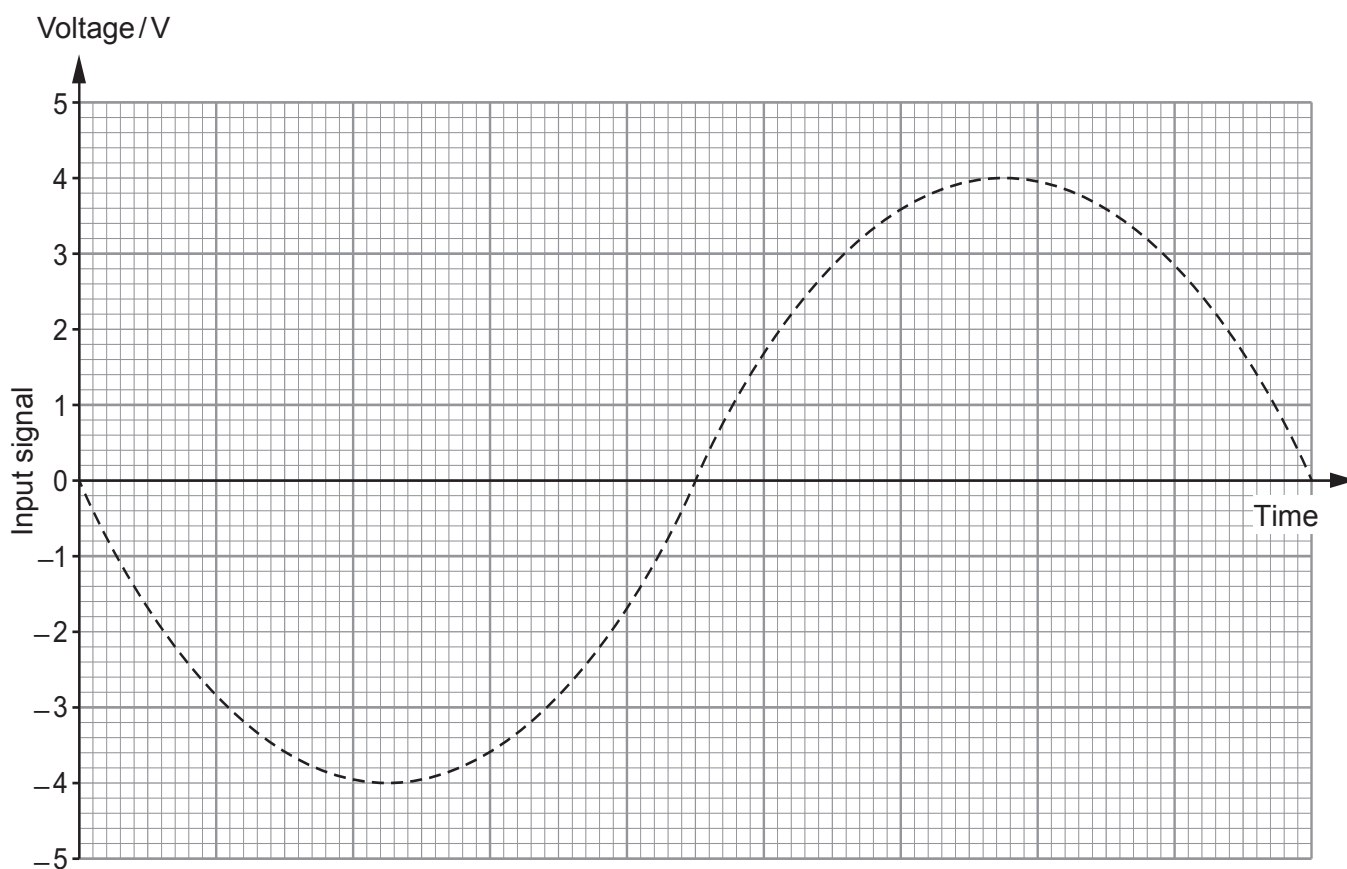

- (iii) The power amplifier output is connected to a $64\ \Omega$ loudspeaker.

Calculate the maximum output power possible from this loudspeaker. [1]

.....

.....

END OF PAPER

BLANK PAGE

BLANK PAGE